

PROJECT: CPG-65538

ITEM NO. 35

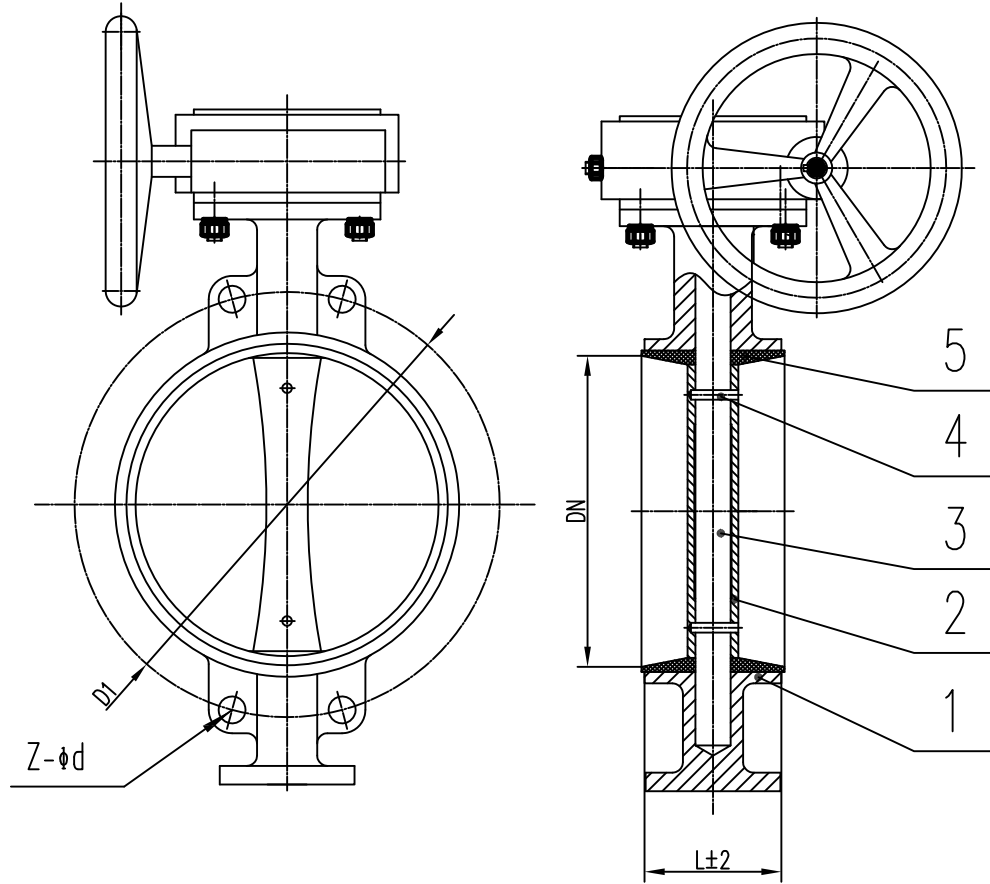

DN	D1	L	Z-d
ø250	ø350	65	12-ø22

Poste: 35

TECHNICAL PARAMETER			
NORMAL PRESSURE	PN10		MPa
WATER	SHEEL	1.5	
WATER	SEALING	1.1	
AIR	SEALING	0.7	
TEMPERATURE	≤80°C		
MEDIUM	WATER, OIL, GAS		

SR.	DESCRIPTION	QTY	MATERIAL	UNIT	TOTAL	REMARK
				WEIGHT		
8	NUT		CS			
7	BOLT		CS			
6	WORM GEAR		CAST IRON			
5	SEAT		XNBR			
4	PIN		13%CR			
3	STEM		13%CR			
2	DISC		STEEL+XNBR			
1	BODY		CAST IRON GG25			

				ASSEMBLY DRAWING			TRANSCEND FLOW CONTROL		
				(TFC Valve)			BUTTERFLY VALVE		
MARK	QTY.	FILE NO.	SIGNATURE	DATE	DESIGN	STANDARD	DRAW MARK	WEIGHT	SCALE
EXAMINE			APPROVE						
TECHNOLOGY					TOTAL: PAGES		NO: PAGE		D371X-PN10